



This manual is for reference and historical purposes, all rights reserved.

This page is copyright© by M. Butkus, NJ.

This page may not be sold or distributed without the expressed permission of the producer

I have no connection with any camera company

On-line camera manual library

This is the full text and images from the manual. This may take 3 full minutes for the PDF file to download.

If you find this manual useful, how about a donation of \$3 to: M. Butkus, 29 Lake Ave., High Bridge, NJ 08829-1701 and send your e-mail address so I can thank you. Most other places would charge you \$7.50 for a electronic copy or \$18.00 for a hard to read Xerox copy.

This will allow me to continue to buy new manuals and pay their shipping costs.

It'll make you feel better, won't it?

**If you use Pay Pal or wish to use your credit card,
click on the secure site on my main page.**



Canon

INTERCHANGEABLE

LENSES

FT

INSTRUCTIONS

English Edition

CANON LENSES



Grand Prix Award



Invention Award

Along with the various models of Canon cameras, Canon lenses have also won wide acclaim for their wonderful photographic performances. Used by camera lovers all over the world, they have displayed their excellent qualities in all fields of photography. The importance of interchangeable lenses is understood and appreciated when the camera is actually being used. Canon's superior skills and techniques have produced a whole series of interchangeable lenses for the Canon Pellix QL, FT QL, Pellix, FX. Gratifying results can be expected from these lenses which are completely free from aberrations, maximum bright, and spectra coated. We invite you to attain satisfaction from these interchangeable lenses.

TYPES OF LENSES

WIDE ANGLE LENS With a wide angle of view and a deep depth-of-field, this lens allows you to photograph expansive scenery, group of people, as well as the interior of buildings, when distance of subject-to-camera is limited. Although the sense of distance will be exaggerated because of the special characteristics of the wide angle lens, its use will produce varied and interesting compositions.

STANDARD LENS This lens is an all-purpose lens. It is ideally suited for scenery, snapshots, portraiture, close-ups, and copying work. Night photography is also easy with brightness of F1.2 or F1.8 lens.

LONG FOCUS LENS Distance is reflected naturally. It is most suitable for portrait

photography in which the hazy background blends beautifully. It is also especially convenient for taking stage pictures, night pictures, and snapping news and sports events as well as merchandise.

TELEPHOTO LENS It is particularly suitable for photographing vivid close-ups of distant scenes and hard-to-reach subject such as mountains and sporting scenes. Besides being excellent for news photography, it may also be used to great advantage for portrait and commercial photography. For a long focus lens, it is comparatively light.

ZOOM LENS It can continuously vary the focal distance, operating functionally like a series of interchangeable lenses. It can be conveniently carried around.

EFFECTS OF INTERCHANGEABLE LENSES (Change of Field-of-View)



35 mm



50 mm



135 mm

When pictures are taken at a given distance with different focal distance lenses illustrated here, the pictorial effects become most pronounced. Generally, as the focal distance increases, while the subject appears larger the scope is narrower. On the contrary, when the focal distance becomes shorter, while the scope widens the subject decreases in size. So if you wish to take a pic-

ture of a group of persons or a large section of a wall in a small room, or a big building, where backing-up space is limited, a short focal distance lens or a wide angle lens, becomes necessary. On the other hand, if you cannot get near a subject or a small section which you wish to sharply photograph, the long focus lens or telephoto lens will produce the desired results.

(Change of perspective)



35 mm



50 mm



135 mm

When photographing the main subject in the same size with different distances by moving the position of camera, the difference in the perspective can be distinctly noticed. The person above-the main subject-is about the same size in each of the snaps, but the background varies widely. The shorter the lens the more the sense of distance becomes exaggerated. There is also a great difference in the obscurity of the background. The use

of a long focus lens brings the subject and background nearer to each other and strongly accentuates the former. Besides the change in field-of-view and perspective, there is also the difference in the depth-of-field in accordance with the size of the lens aperture. Ultimately the key to better pictures is to fully utilize—as circumstances demand—the three types of lenses: wide angle, standard and telephoto.

HOW TO USE THE LENS

1 Automatic diaphragm and manual diaphragm

The FL series of interchangeable lenses have been designed for the exclusive use of Canon SLR cameras. The pre-set automatic diaphragm type is in use for these lenses, but only the 19 mm-a special type of lens-is the manual diaphragm type. In the case of the automatic diaphragm lens, when the shutter button is pressed, the diaphragm is closed automatically to the pre-selected aperture stop position. When the shutter operation is completed, it automatically reopens to full aperture opening. For manual aperture control, each of lenses is equipped with either A-M ring or pre-set aperture release ring. In case of telephoto lenses, some lenses are equipped with pre-set aperture release button instead of release ring.

5

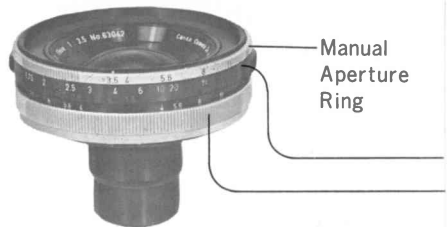

1. Manual <For 19mm F3.5>

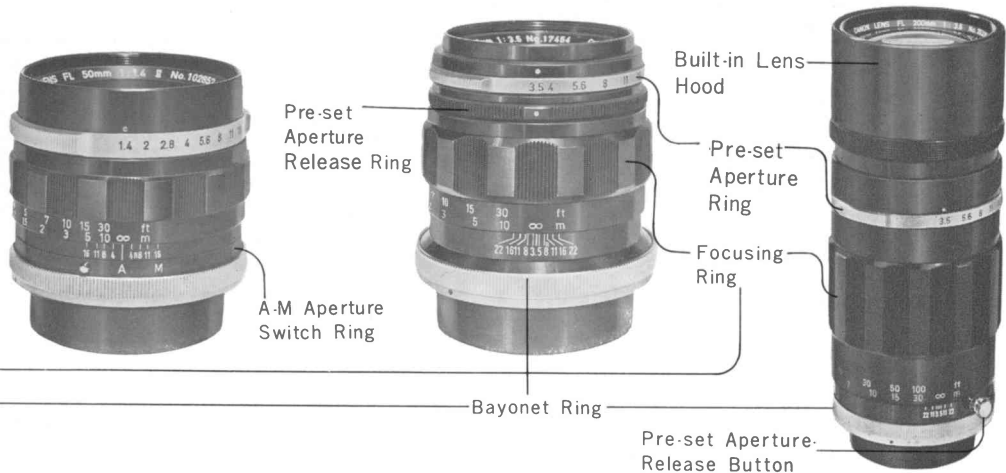

2. Automatic <For Lenses With A-M Aperture Switch Ring >

3. Automatic <For Lenses With Automatic Aperture Release Ring >

4. Automatic <For Lens With Pre-set Aperture Release Button >

2 Diaphragm Operation

● Pre-set diaphragm

Automatic diaphragm

This is the mechanism for adjusting the size of aperture. If the pre-set aperture ring is turned and set the desired F-stop to the index, the lens is closed down to the preselected aperture stop for the instant when the shutter is released. Ordinarily, the diaphragm is full opening.

● Pre-set diaphragm release

Manual diaphragm 1

Lens with Automatic/Manual aperture ring such as 50 mm F 1.4 can be completely switched over to manual aperture control at "M" position.

Desirable F stop can be set with pre-set aperture ring. At "A" mark position, it works as automatic mechanism.

At "M" mark position, it works as manual.

Manual diaphragm 2

When the pre-set aperture is released, the diaphragm closes down to the pre-selected aperture stop. So the depth-of-field at a certain aperture can be checked.



Diaphragm worked by turning
the pre-set aperture ring

-
- ※ Do not turn the manual aperture ring when the pre-set aperture ring is at full opening.
 - ※ After checking the lens aperture, return the manual aperture ring to open.



Manual diaphragm 3

The lens aperture can be seen by pressing the release button. When finger is removed, the diaphragm reopens to full aperture opening.

DEPTH-OF-FIELD

DEPTH-OF-FIELD This is the scope of sharpness in front and behind a subject focused. This scope will vary with the F-stop selected. For instance, when the subject is focused at a distance of 3 m with a 50 mm lens, using an aperture of F8, the distance on both sides of the index of 8 will read approximately 2.3 m and 4.3 m respectively, indicating that the subject will be clearly photographed within that distance. Similarly, when the aperture is dropped to F16, the distance within focus will range from 1.9 m to 7.6m. The depth-of-field will be deeper...

the smaller the lens aperture.

the shorter the lens focal distance.

the farther the distance of the subject.

The depth-of-field can be seen by adjusting the manual aperture ring in the FL lenses.



Depth-of-Field Scale
Distance Index Mark
Distance Scale

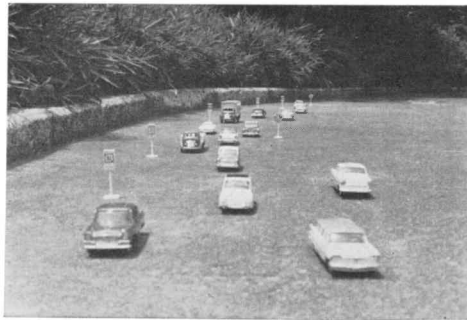
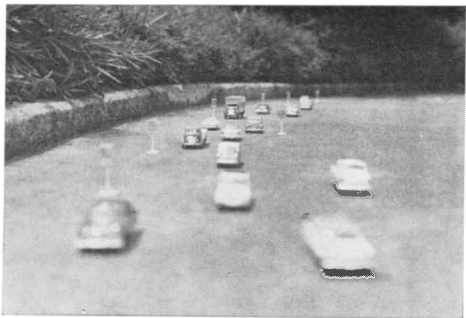

F8 50 mm
Depth-of-Field about 2.3 m-4.3 m
Focused at 3 m



F16 50 mm
Depth-of-Field about 1.9 m-7.6 m
Focused at 3 m



LENS gets darker in direct proportion to the increase in the numerical value of aperture scale. One F-stop difference on the aperture scale normally means double or one-half of the light amount. Thus, when the aperture is dropped by one F-stop, the exposure time must be doubled, or when the aperture is dropped by two F-stops the exposure time must be increased four times. Intermediate points on the aperture scale may also be used. There are some lenses which do not reduce the light amount by one-half only between the aperture stop of the largest opening and the next stop on the scale.



Aperture Stop	1.2	1.4	1.8	2.0	2.8	(3.5)	4.0	5.6	8.0	11	16	22
Exposure Ratio	2.7	2	1.25	1	1/2	(1/3)	1/4	1/8	1/16	1/32	1/64	1/128

Distance scale reading indicates the distance between the subject in focus and the surface of the film.

INFRARED INDEX MARK R Infrared photography being different from ordinary photography, slight modifications must be made in the position of the focus. First of all, set the focus in the usual manner. Then, fix that distance to the infrared index mark "R". The infrared mark is indexed on the basis of the use of a film with the greatest sensitivity to a wave-length of about 8000\AA and an infrared filter. (for instance, Kodak IR 135 film and Wratten 87 filter or the JIS IR 77-78 filter). For instance, when the plus X or the general panchromatic film with an infrared filter of Wratten 25 or SR 59~60 attached is used, the proper amount of correctional movement is about $1/3$.

If the focus is adjusted at 10 on the distance scale, simply move the 10 mark to the "R" position.

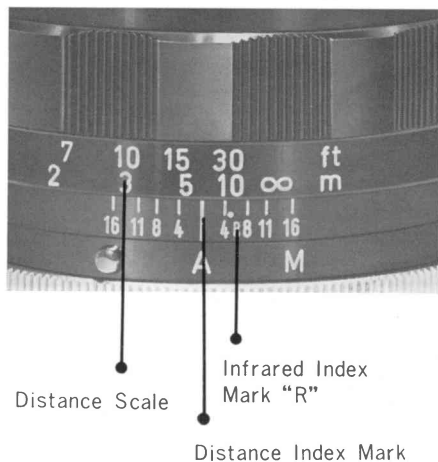

CHANGING OF LENS



HOW TO REMOVE THE LENS After turning the bayonet ring to the left, pull it out toward the front.

HOW TO MOUNT THE LENS Make the insertion after fitting the red dots of the camera and lens, then tighten by turning the bayonet ring to the right.

- Unless the red dot of the lens is placed above the distance index, insertion will not be possible.
- There is a pre-set aperture lever at the back end of the lens. As this lever opens and closes the aperture, when removing the lens, be sure to protect this important piece by covering it with the dust cap.

※When the lens has been removed, be careful not to touch the mirror with the finger. When the camera is not being used for a long time, always have it covered.

※When mounting the 19 mm, first of all turn the mirror lock lever of the camera upward. In this case, take special precaution to block light and make the change as quickly as possible.

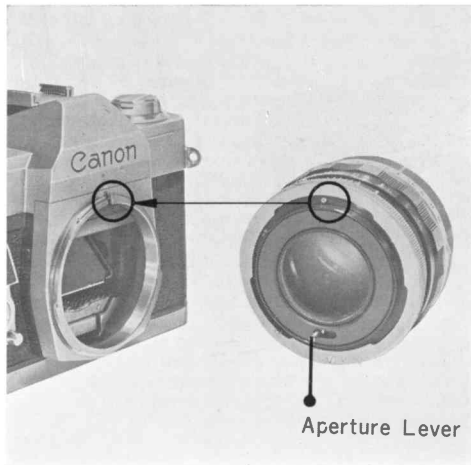

FL 50mm. F 3.5
with life size adapter

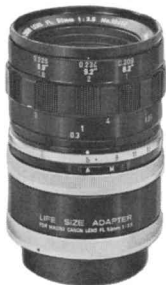

FLP 38mm F2.8

MACRO CANON LENS FL 50 mm F3.5

A lens of super high resolving power. Aside from its high delineation power in general photography, it is especially effective when used in close-up, copy and macrophotography. Its large protruding length makes possible close-up shots up to approximately 23 cm. Moreover, life-size pictures can be taken with the life-size adapter, which comes as an accessory. The lens is so designed that, in close-up photography, you only have to follow the indication of the meter needle because of the automatic exposure correction mechanism.

CANON LENS FLP 38 mm F2.8

A semi wide-angle lens exclusively for the Pellix QL with its stationary pellicle mirror. It is most ideally designed for taking snapshots. The stationary mirror has made possible the installation of the optical system inside the body and has reduced the protruding length. This lens cannot be used on other cameras because the movable mirrors get in the way.

INTRODUCTION OF NEW CANON LENSES



FL 28mm F 3.5

CANON LENS FL 28mm F 3.5 (7 element in 7 component lens composition) New long awaited super wide angle lens from Canon. It is designed to be compact, light and sharp with angle of view of 75°. Sufficient in quantity of marginal light beam and gives clear images. Introduction of this lens completely systematizes interchangeable lenses for Canon SLR cameras.

17

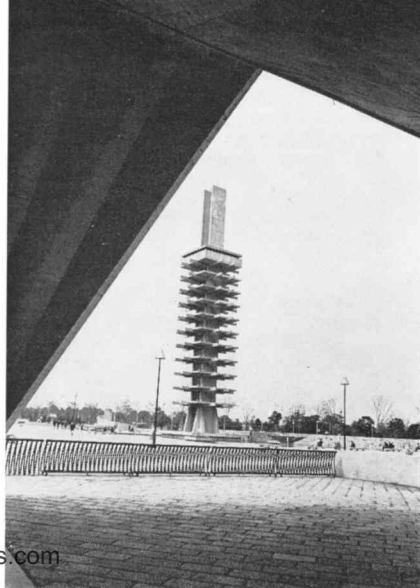

NEWLY DEVELOPED COMPACT LIGHTWEIGHT TELEPHOTO LENSES



FL 135mm
F 3.5



FL 200mm
F 4.5



FL 100~200mm
F 5.6

CANON ZOOM LENS FL 100mm-200mm F 5.6 (8 element in 5 component lens composition) (with built-in lens hood)

The latest edition to Canon compact series lenses.

Designed compact, light, it is suitable to take scenery, snapshots.

Adopted with optical compensation system, zooming can be made by just protruding the lens.

FL Lens 135 mm F 3.5 (4 element in 3 component lens composition)

FL Lens 200mm F 4.5 (5 element in 4 component lens composition) (with built-in hood)

Compact, lightweight lenses with high resolving power at reasonable price.

Proudly recommend these lenses for taking distant scenes and hard-to-reach subject.

Revolutionary new editions to Canon interchangeable FL series lenses.

FILTERS

Filters are indispensable in photography. Various types of filters are available for you to choose from according to your needs.

TYPE	EFFECTIVENESS OF FILTERS
UV (SL 39 · 3C) for black & white and color Y1 (SY 44 · 2C) Y3 (SY 50 · 2C) } for black G1 (MG 55C) } & white O1 (SO 56 · 2C) R1 (SR 60 · 2C) for black & white and infrared Skylight } for black & white ND4 } and color ND8 } Color Conversion A } for color Color Conversion B }	<ul style="list-style-type: none"> • Absorbs only ultra-violet rays. Especially effective at seaside and high mountains where ultra-violet rays are in abundance. Recommended for use in color photography. • Increases contrast of monochrome film. Regulates the color of the sea, subdues the blue sky and makes the white clouds stand out. Slightly brightens red and yellow. • Prevents red from turning radically into white. Lightens faces and sky appropriately, and reflects the brightness of fresh greenery as seen with the naked eye. • Blue is greatly darkened, and yellow and red are made much brighter than when seen with the naked eye. Good for contrasts, especially in distant landscapes. • Makes strong contrasts. In some cases it makes daylight shots look like night shots. May also be used with infrared film. • Brings the colors of the blue sky and shade much closer to their natural colors. • ND4 reduces light volume by 1/4, ND8 by 1/8. Has absolutely no effect on the reproduction of colors of color film. • Color film filter for conversion of color temperature when photographing with tungsten type film under sunlight. • Color temperature conversion filter for use with daylight type color film under tungsten light.

PROPER CARE OF LENSES

- Avoid changing lens in direct sunlight. Make the change as quickly as possible. It is important to do this in the shade, but in unavoidable circumstances shade the camera with your body.
- Avoid dust and other particles adhering to the surface of the washer between the camera and lens. When the lens has been removed, immediately put the dust cap.
- When dust gathers on the surface of the lens, remove this gently with a clean soft feather. Should it be very soiled, wipe the lens with the clean cotton cloth lightly dabbed in alcohol. Gently wipe with the cloth. By rubbing strongly or using dirty cloth, the lens will be scratched.
- Avoid keeping the lens in a warm and humid place for a long period. In such cases, store it together with a desiccant such as silica gel.

CANON BELLOWS FL

Canon Bellows FL is attached to Canon single-lens reflex cameras Pellix QL, FTQL, Pellix, FX for extreme close-up photography. It is a high performance bellows adjustment apparatus that has a shooting distance precision adjustment mechanism and a mechanism coupled to the diaphragm of the FL lens.

LENS HOOD

When taking pictures, always use the lens hood. It blocks harmful light.

LEATHER CASE

The hood for a telephoto lens can be inversely capped and then be placed in the case.

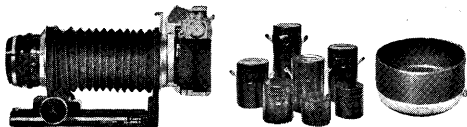

TABLE OF INTERCHANGEABLE LENSES FOR CANON SINGLE LENS REFLEX CAMERAS

Lens	Type	Angle of view	Aperture System	Pre-set aperture release mechanism	Magnification for standard lens	Lens Composition	Minimum aperture	Distance scale		Attachment size (mm)		Hood	Case	Coating	Weight (grams)
								In feet	In meters	Cap size	Filter size				
FL 19mm F3.5	Super wide angle	96°	Manual	—	0.38×	9 elements in 7 components	16	1.75-20 [∞]	0.5-7 [∞]	60	58	—	Exclusive	Magenta, Purple	150
FL 19mm F3.5R	Super wide angle	96°	Automatic	By A-M ring	0.38×	11 elements in 9 components	16	1.75-20 [∞]	0.5-7 [∞]	80	Series No. 9	—	Exclusive	Amber	500
FL 28mm F3.5	Super wide angle	75°	"	By A-M ring	0.56×	7 elements in 7 components	16	1.5-10 [∞]	0.4-3 [∞]	60	58	W-60-B	C	Amber	240
FL 35mm F2.5	Wide angle	64°	"	By aperture release ring	0.7×	7 elements in 5 components	16	1.5-10 [∞]	0.4-3 [∞]	60	58	W-60-A	C	Magenta	352
FLP38mm F2.8	Wide angle	59°	"	By aperture release ring	0.76×	4 elements in 3 components	16	3-30 [∞]	0.8-8 [∞]	60	48	—	Exclusive	Magenta	210
FL 50mm F3.5	Macro	46°	"	By A-M ring	1×	4 elements in 3 components	22	9.2(in) -20 [∞]	0.234-5 [∞]	60	58	S-60	Exclusive	Amber	295
FL 50mm F1.8	Standard	46°	"	By A-M ring	1×	6 elements in 4 components	16	2-30 [∞]	0.6-10 [∞]	50	48	S-50	C	Magenta, Purple	280
FL 50mm F1.4 II	Standard	46°	"	By A-M ring	1×	7 elements in 6 components	16	2-30 [∞]	0.6-10 [∞]	60	58	S-60	C	Amber, Purple	340
FL 58mm F1.2	Standard	41°	"	By aperture release ring	1.2×	7 elements in 5 components	16	2-30 [∞]	0.6-10 [∞]	60	58	S-60	C	Amber	410
FL 85mm F1.8	Long-focus	29°	"	By aperture release ring	1.7×	5 elements in 4 components	16	3.5-60 [∞]	1-20 [∞]	60	58	T-60-2	D	Magenta, Purple	445
FL100mm F3.5	Telephoto	24°	"	By aperture release ring	2×	5 elements in 4 components	22	3.5-30 [∞]	1-10 [∞]	50	48	T-50-2	H	Purple	278
FL135mm F3.5	Telephoto	18°	"	By A-M ring	2.7×	4 elements in 3 components	22	5-100 [∞]	1.5-30 [∞]	50	48	T-50-2	E	Magenta	434
FL135mm F2.5	Telephoto	18°	"	By aperture release ring	2.7×	6 elements in 4 components	16	5-100 [∞]	1.5-30 [∞]	60	58	T-60-2	F	Magenta	645
FL200mm F3.5-2	Telephoto	12°	"	By aperture release button	4×	7 elements in 5 components	22	8-100 [∞]	2.5-30 [∞]	60	58	Built-in	G	Magenta	680
FL200mm F4.5	Telephoto	12°	"	By A-M ring	4×	5 elements in 4 components	22	8-100 [∞]	2.5-30 [∞]	50	48	Built-in	Exclusive	Magenta, Purple	555
FL55-135mm F3.5	Zoom	43°-18°	"	By aperture release button	1.1-2.7×	13 elements in 10 components	22	7-100 [∞]	2-30 [∞]	60	58	S-60	Exclusive	Amber	790
FL100-200mm F5.6	Zoom	24°-12°	"	By A-M ring	2-4×	8 elements in 5 components	22	8-100 [∞]	2.5-30 [∞]	57	55	Built-in	Exclusive	Magenta	650
FL85-300mm F5	Zoom	29°-8°	"	By aperture release button	1.7-6×	15 elements in 9 components	22	12-200 [∞]	4-50 [∞]	75	72	Built-in	Exclusive	Magenta	1,840